

Stacker Options

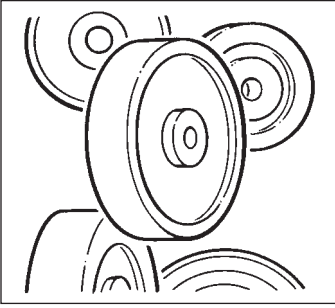

Wheel Material:

Standard wheels are phenolic plastic. For steel or hard rubber wheels add \$40.00, for polyurethane wheels add \$90.00, molded rubber add \$90.00.

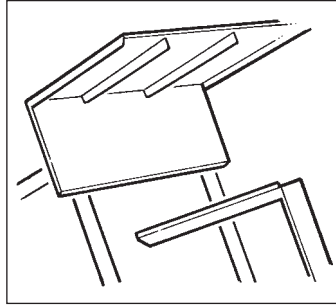

Reversed Forks:

Ideal for overhead installation. Forks can be modified in a reverse position giving an increased lowered / raised height. \$170.00

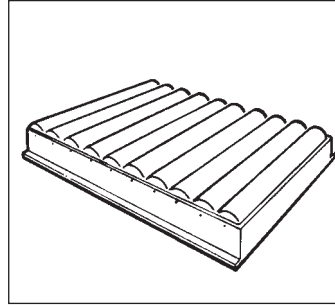

R-5 Roller Bed:

Excellent for transferring heavy objects to/from lift with minimum effort. Front or side loading. Rollers on 3" center. 27" x 30" area, mounted on a 32" x 30" platform. 1000 lb. cap. R-5: Weight 145 lbs. \$360.00. (Requires 18" LC.)

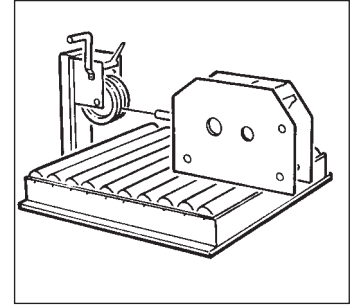

P-6 Die Puller:

Equipped with hand operated winch with cable and hook for pulling dies over roller bed. 27" x 30" roller area mounted 32" x 30" platform. 1000 lbs. capacity. P-6: Weight 185 lbs. \$500.00 (Requires 18" LC.)

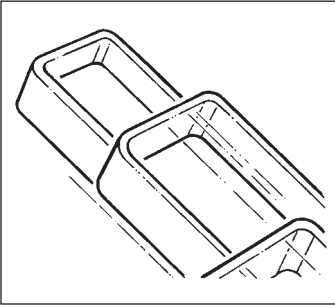

Height:

Standard lift heights can be decreased to meet special handling requirements. Add \$250.00 per foot or any portion of a foot on all fixed mast units. For telescopic mast units consult factory.

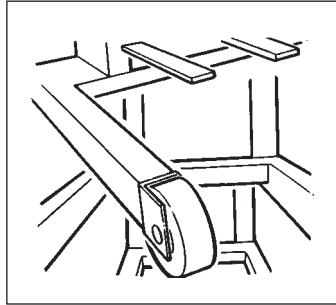

Base Legs:

Standard straddle dimensions can be increased or decreased to fit any size pallet or load. Available on straddle fork models only. Up to 42" I.D. add \$140.00. Over 42" I.D. add \$180.00.

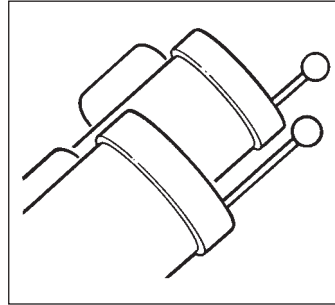

Larger Motor - AC:

Doubles lifting speed on Presto AC Electric Lifts; 1 Phase, 60 Cycle, 220V, 2HP or 2HP, 220/440V, 3 Phase, 60 Cycle AC motor. Larger unit available. Consult factory.

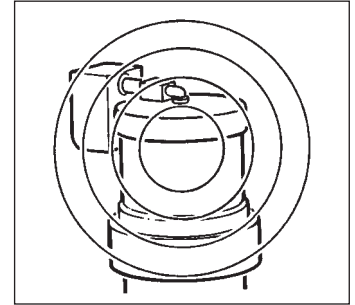

Hazardous Location Motors:

Special motors and fittings are available for all stationary AC electric lifts. U.L. Approved. Class I Group D. Class II, Groups F & G add \$650.00 (Engineering approval required).

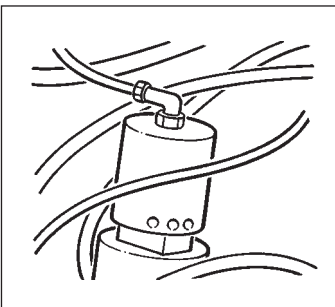

Air Power:

Optional air motors that operate from your factory's airline supply are available. At 1000 lbs. capacity add \$470.00. At 1500, 2000 and 2700 cap. add \$700.00. NOTE: Air power without remote control unit has no cabinet door. (For remote hand control add \$270.00.)

